

THIS DRAWING IS UNPUBLISHED. RELEASED FOR PUBLICATION
 © COPYRIGHT - By - ALL RIGHTS RESERVED.

LOC	DIST	REVISIONS					
AJ	16	P	LTR	DESCRIPTION	DATE	DWN	APVD
			H1	REVISED PER ECO-11-005030	23MAR11	RK	HMR

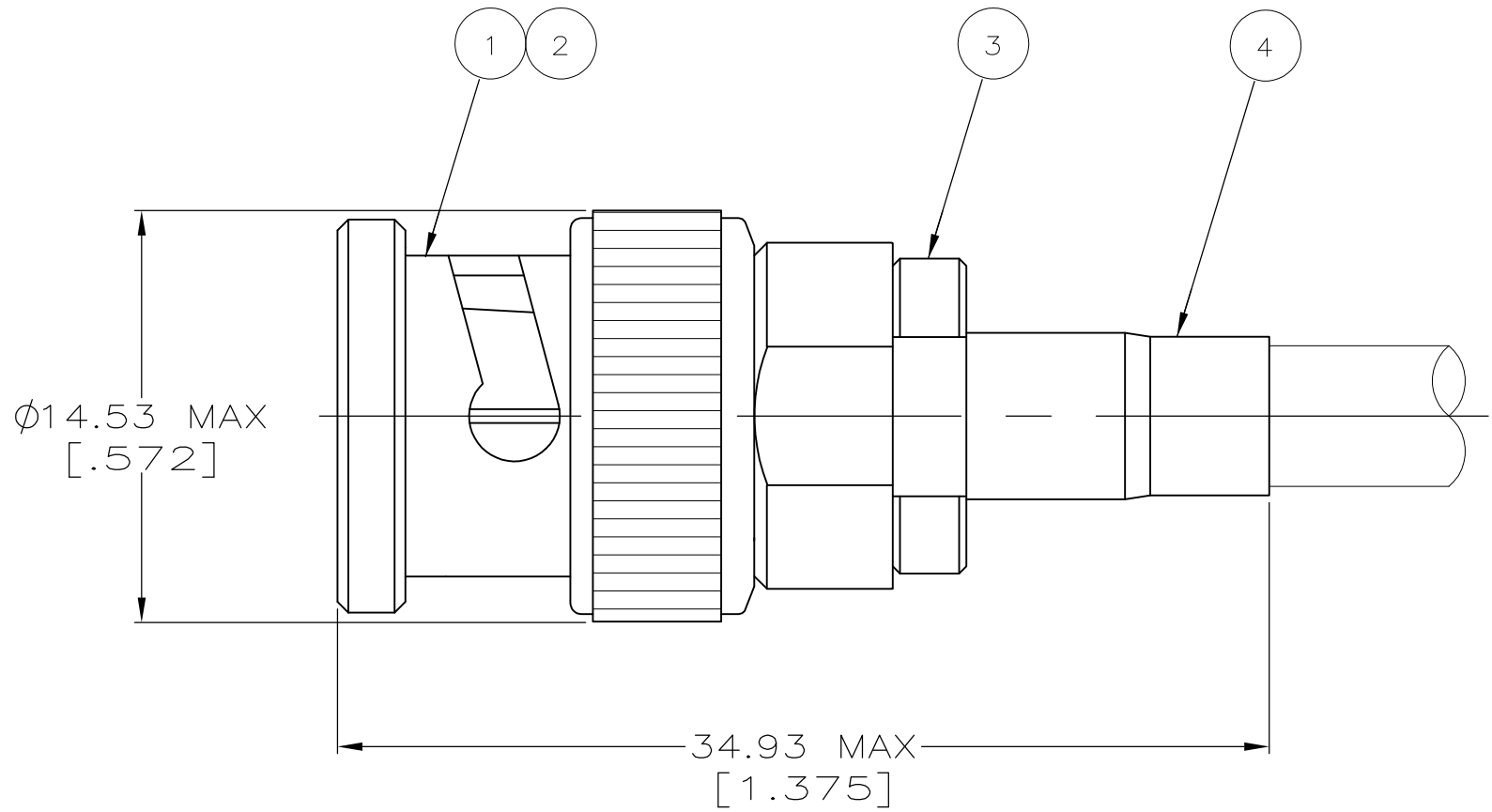

- 1. USE INSTRUCTION SHEET 1799-1
- ② USE CRIMP TOOL 69140-1 WITH CABLE RG-58/U, 58A/U, 58B/U, 58C/U
- ③ USE CRIMP TOOL 69140-2 WITH CABLE RG-55/U, 55A/U, 55B/U AND 223/U

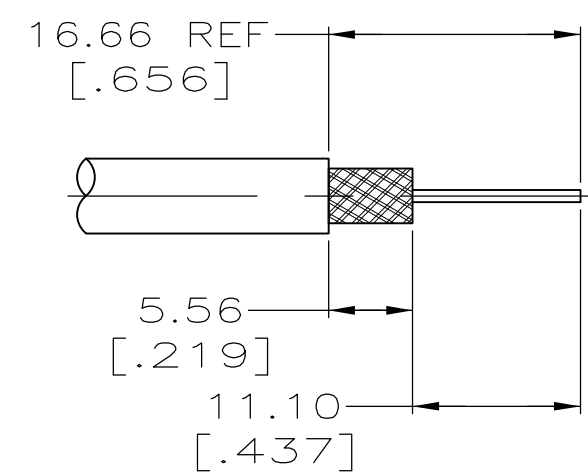

RECOMMENDED STRIP LENGTH
SCALE 2:1

OBSOLETE	-	-	-	-	7-329444-1
③	329099	50780-1	2-329106-1	329804	2-329444-2
②	328663	50780-1	2-329106-1	329804	2-329444-1
SUPERSEDED BY 2-329444-1					
④	FERRULE QTY=1	③	CRIMP END ASSEMBLY QTY=1	②	GASKET QTY=1
				①	PLUG ASSEMBLY QTY=1
					PART NUMBER

THIS DRAWING IS A CONTROLLED DOCUMENT.

DIMENSIONS: mm [INCHES]	TOLERANCES UNLESS OTHERWISE SPECIFIED:	DWN MICHAEL E. COWHER 06FEB96	TE Connectivity NAME PLUG, BNC
	0 PLC ± - 1 PLC ± - 2 PLC ± 0.41 [.016] 3 PLC ± - 4 PLC ± - ANGLES ± -	CHK FRANK P. MORANA 15FEB96	
MATERIAL	FINISH	APVD FRANK P. MORANA 15FEB96	
		PRODUCT SPEC APPLICATION SPEC	
		WEIGHT	SIZE A3
			CAGE CODE 00779
			DRAWING NO C-329444
			RESTRICTED TO
			SCALE 4:1
			SHEET 1 OF 1
			REV H1

CUSTOMER DRAWING