

DRAWING MADE IN THIRD ANGLE PROJECTION

THIS DRAWING IS UNPUBLISHED. RELEASED FOR PUBLICATION .19

© COPYRIGHT 19 BY AMP INCORPORATED. ALL INTERNATIONAL RIGHTS RESERVED.

LOC	DIST	P	F	ZONE	LTR	REVISIONS	DATE	APPD
DF	TO				0	RELEASED	1-14-89	
					A	REV. PER ECN DF-1335	1-24-89	JMN
					B	REV. PER ECN DF-1390	2-2-89	JMN

#0-80 UNF-2B
.135 DEEP

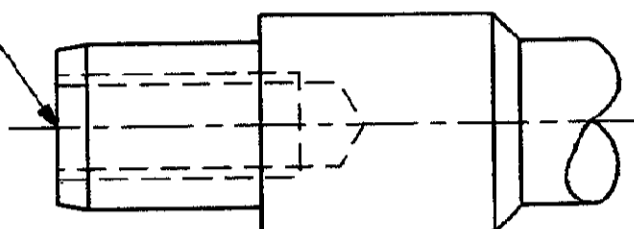

△ FOR DASH-2 ONLY

- △1 MATERIAL: STAINLESS STEEL PER ASTM-A-582.
- △2 PASSIVATED PER QQ-P-35.
- △3 SAME AS DASH-1 EXCEPT AS NOTED.

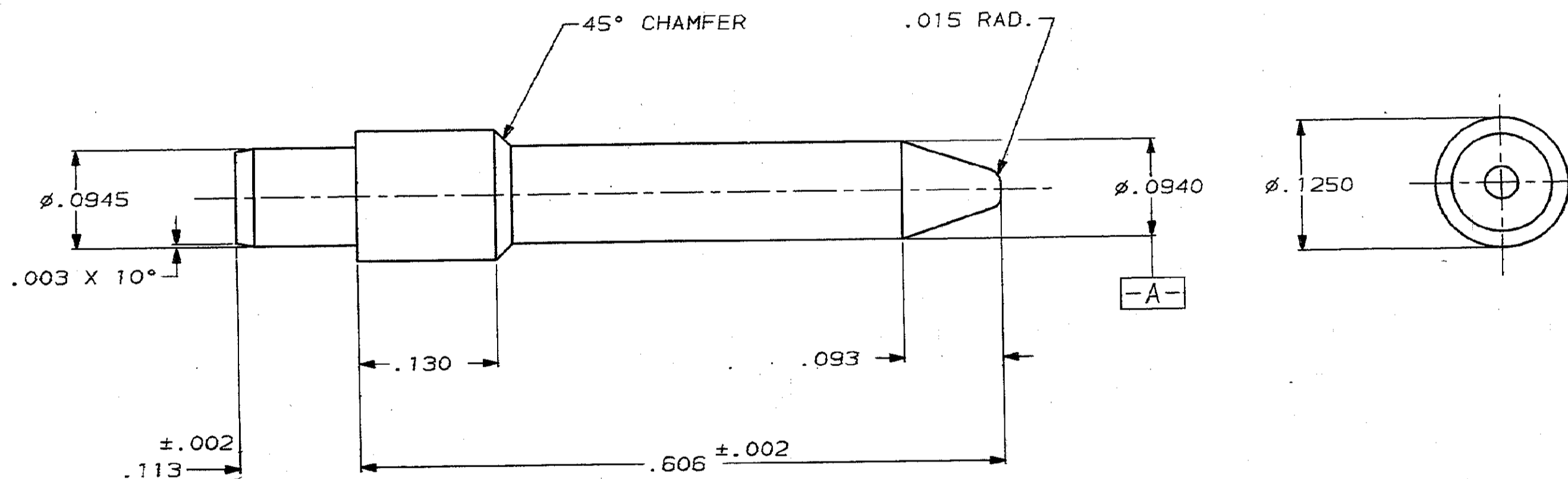

△3	△2	△1	445287-2
AS SHOWN	△2	△1	445287-1
NOTE	FINISH	MATERIAL	PART NO.

DO NOT SCALE PRINT. UNLESS SPECIFIED .005 TOLERANCES ON: 3 PLC DEC ± .005 4 PLC DEC ± .0005 ANGLES ± 1°	DR B.W. BLAIR 1-16-89	AMP AMP INCORPORATED Harrisburg, Pa. 17105	
	CHK J.S. MARGOSIAK 1-17-89		
MATERIAL △1	APPD J.S. MARGOSIAK 1-17-89	PRODUCT SPEC -	
FINISH △2	APPD D.E. SMITH 1-17-89	APPLICATION SPEC -	
	WEIGHT -	SIZE C	FSCM NO 00779
		SCALE 10:1	DRAWING NO 445287
			SHEET 1 OF 1

CUSTOMER DRAWING