

PART NAME: KNOB SCALE: 1:1 DATE: 3/9/2000 DR. BY ST

THIS DRAWING IS THE PROPERTY OF DAVIES MOLDING COMPANY, IS SUBMITTED SOLELY AS A DESIGN OR ENGINEERING PROJECT. WE ACCEPT NO RESPONSIBILITY WHATSOEVER FOR THE PRACTICAL APPLICATION OF THE PIECES MADE TO THIS DESIGN.

DAVIES MOLDING COMPANY
CAROL STREAM, ILLINOIS 60188

P/N	1400CX
BASE PART	1400-30
SPRING	I1125A

SCALE 2 : 1

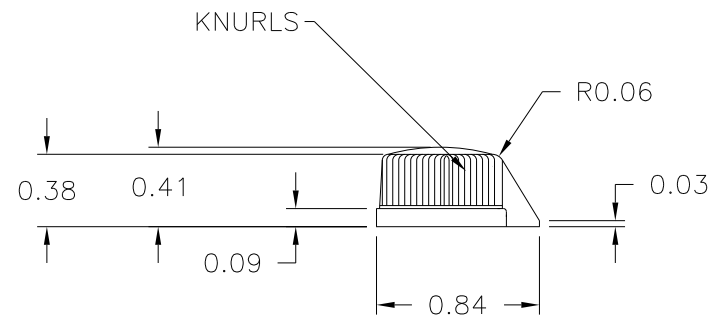
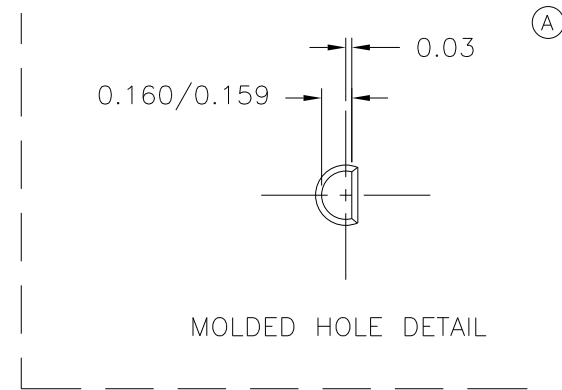
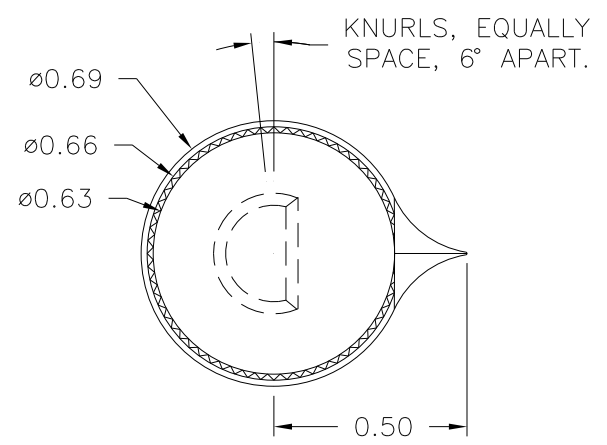

SECTION A-A

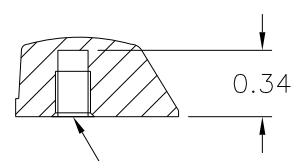

"D" SHPED SPRING INSERT I1125A,
SPRING MOUNTING TO FIT $\phi 1/4$
SHAFT FLATTED TO 0.156.

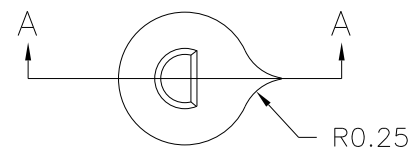

MATERIAL: #2567 PHENOLIC (R67)
COLOR: RED

TOLERANCES: UNLESS OTHERWISE SPECIFIED	DO NOT SCALE DRAWING			
DECIMALS: X.XXX ± .005 X.XX ± .015	MM: X.XX ± 0.15MM X.X ± 0.4MM	A	ADDED BASE PART	JAM 5/29/14
FRACTIONS ± 1/64	ANG. ± 1°	CHANGES		